

# WORLD MARKET®

## Assembly Instructions

BUNDLE - RECYCLED PLASTIC ADIRONDACK  
3 PC SET

SKU 1023

2x	RECYCLED PLASTIC ADIRONDACK NATURAL
1x	RECYCLED PLASTIC SIDE TABLE NATURAL

See following pages for individual  
component assembly instructions

# WORLD MARKET®

## Assembly Instructions

Recycled Plastic Adirondack Chair



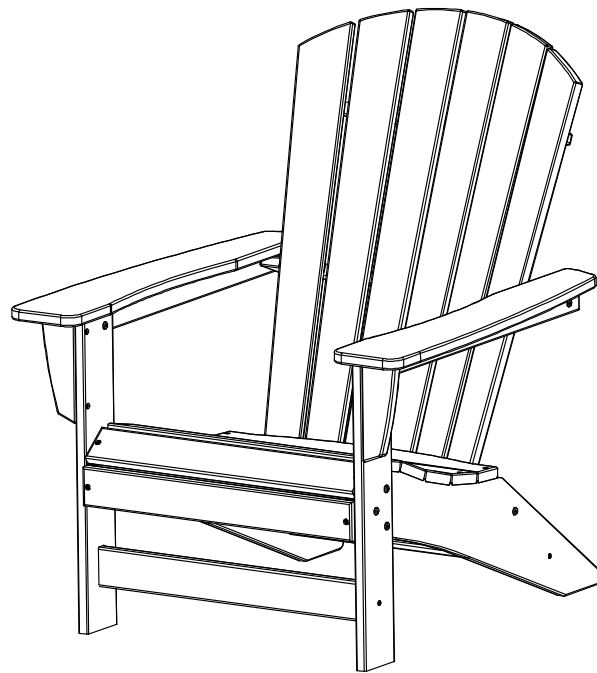



SKU 630947, 630948, 631438, 631439



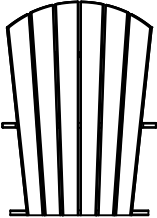
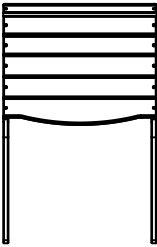
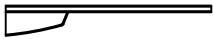

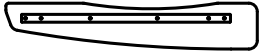

Thank you for your purchase. If you have any questions pertaining to the assembly of this furniture piece, please contact the nearest World Market store. If you are not near a store, please call our customer service call center toll free at 877-967-5362 for assistance.

ALL PRODUCTS SOLD AT WORLD MARKET ARE NOT  
FOR COMMERCIAL USE AND ARE INTENDED FOR  
RESIDENTIAL USE ONLY.

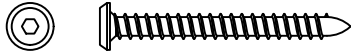
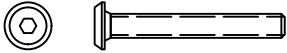
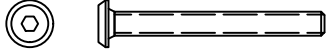

# Component List

LABEL	PICTURE	DESCRIPTION	QTY.
A		Back	1
B		Seat Assembly	1
C		Left Front Leg	1
D		Right Front Leg	1
E		Left Arm	1
F		Right Arm	1
G		Back Brace	1
H		Front Brace (Longer)	1

# Hardware List

LABEL	PICTURE	DESCRIPTION	QTY.
H-1		Lag Screw 1/4" x 2-1/2"	4
H-2		Small Machine Screw 1/4"-20 x 1-7/8"	6
H-3		Large Machine Screw 1/4"-20 x 2-1/4"	2
H-4		Phillips Screw #8 x 1-1/2"	4
H-5		Nylon Lock Nut	8
H-6		Washer	8

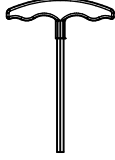
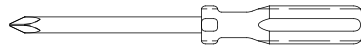
# Tool List

LABEL	PICTURE	DESCRIPTION	QTY.
T-1		T-Handle Allen Wrench	1
T-2		#2 Phillips Screwdriver (Not Included)	
T-3		7/16" Wrench (Not Included)	

# Assembly Preparation

## Before Beginning:

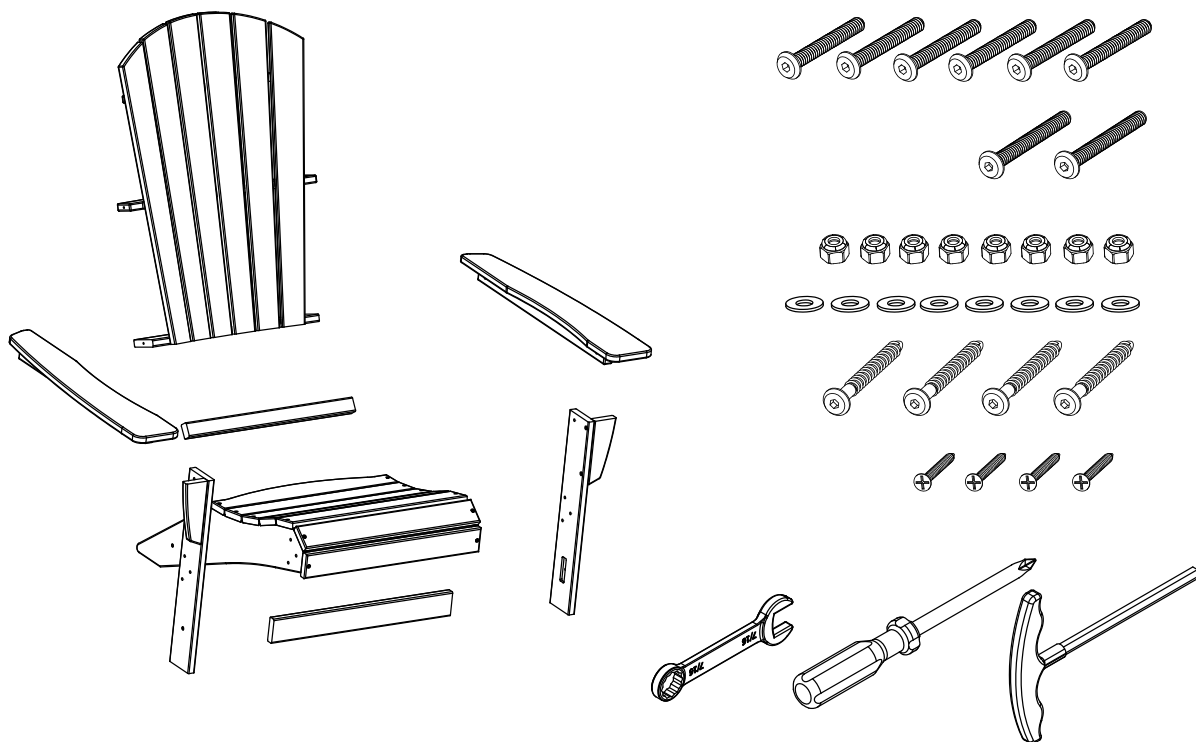

Unpack all hardware bags and components to ensure you have all parts. Take note of bolt hardware size differences and components that may have directional labels (Example: TOP or FRONT).



Read the assembly instructions, cover-to-cover. Save any **Care and Maintenance** instructions pages for after the assembly has been completed.



It is always recommended to have 2 adults on hand for assembly.



Do not assemble on hard, abrasive flooring or carpeted surfaces that can damage or get caught in the components during assembly.

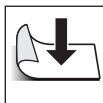

Assemble on a clean non-marring surface (such as the product's packing foam).

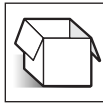

Do not discard any packaging until the product has been fully assembled.



In case of missing parts, please contact your nearest World Market store or call our customer service call center at 1-877-967-5362.



**WARNING:** Small parts are a choking hazard. Adult supervision is required before, during, and after assembly.

# Assembly Steps

## Step 1



(H-4) Phillips Screw x 2

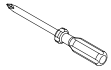

(T-2) Phillips Screwdriver

**IMPORTANT:**

Use the longer Front Brace (H), instead of the shorter Back Brace (G).

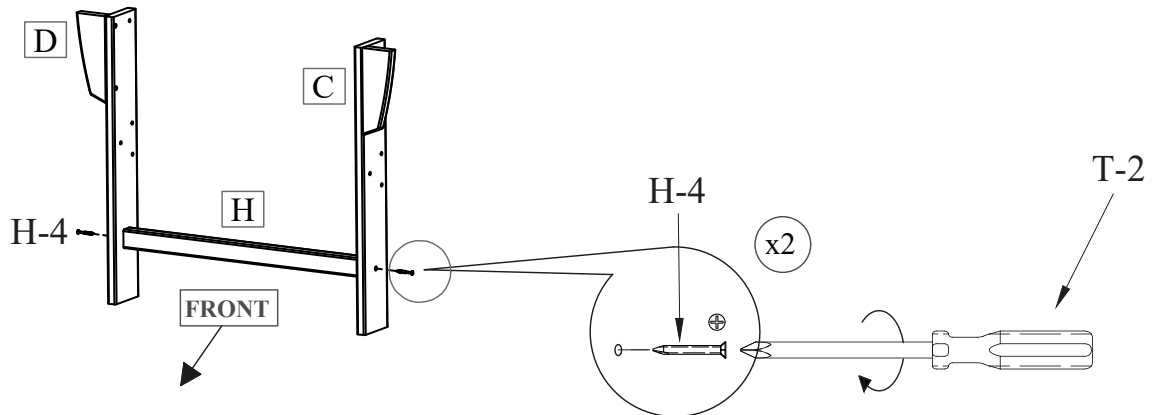

Install the longer Front Brace (H) into the Right Front Leg (D). Fasten using the Phillips Screw (H-4) with a Phillips Screwdriver (T-2). Fit the longer Front Brace (H) into the Left Front Leg (C). Fasten using the Phillips Screw (H-4) with a Phillips Screwdriver (T-2). Do not yet fully tighten.

## Step 2



(H-1) Lag Screw x 2



(T-1) T-Handle Allen Wrench

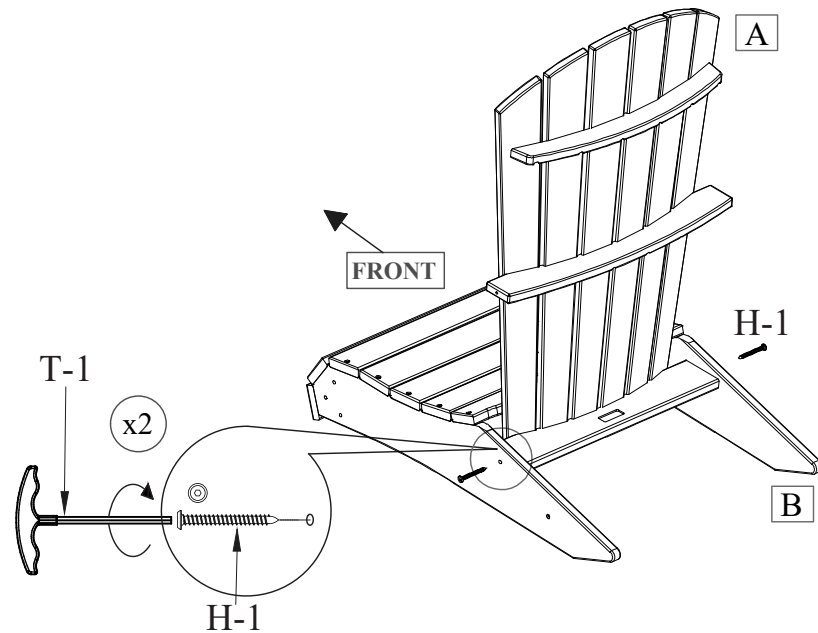

Install the Back (A) by fitting it into the pockets of the back of the Seat Assembly (B). Fasten using a Lag Screw (H-1) on each side with the T-Handle Allen Wrench (T-1). Do not yet fully tighten.

# Assembly Steps

## Step 3

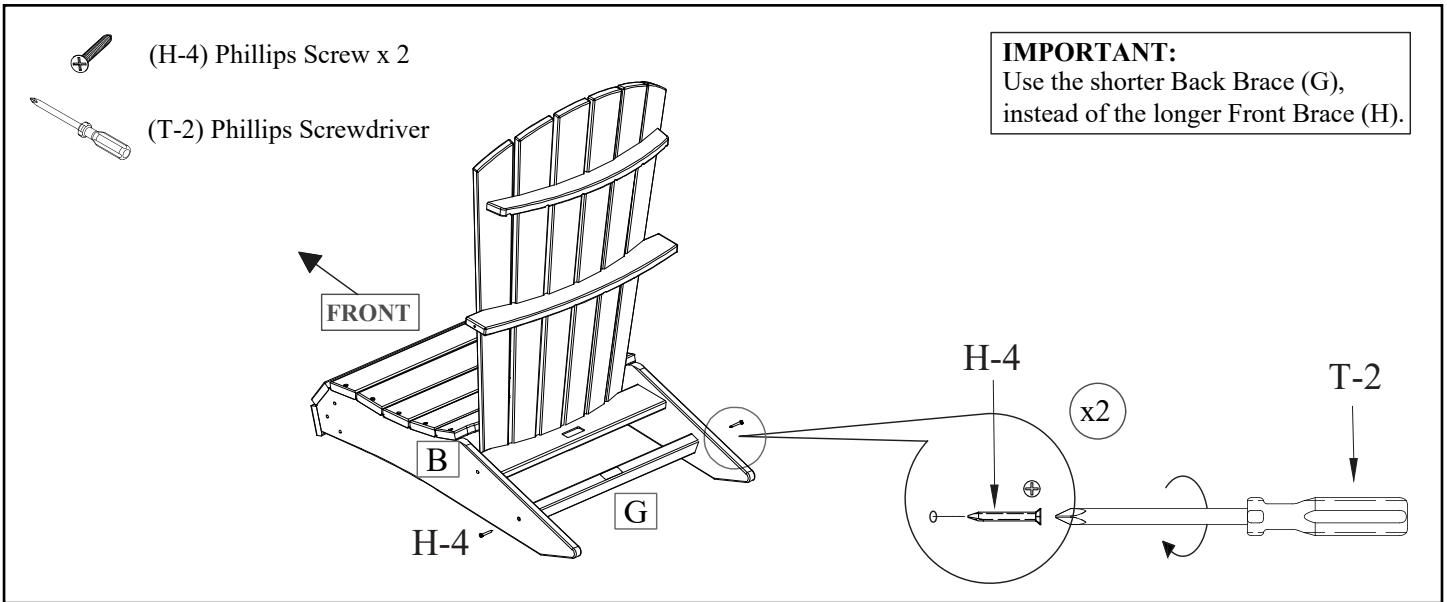

Install the shorter Back Brace (G) into the pockets of the Seat Assembly (B). Fasten using a Phillips Screw (H-4) with a Phillips Screwdriver (T-2) on each side. Do not yet fully tighten.



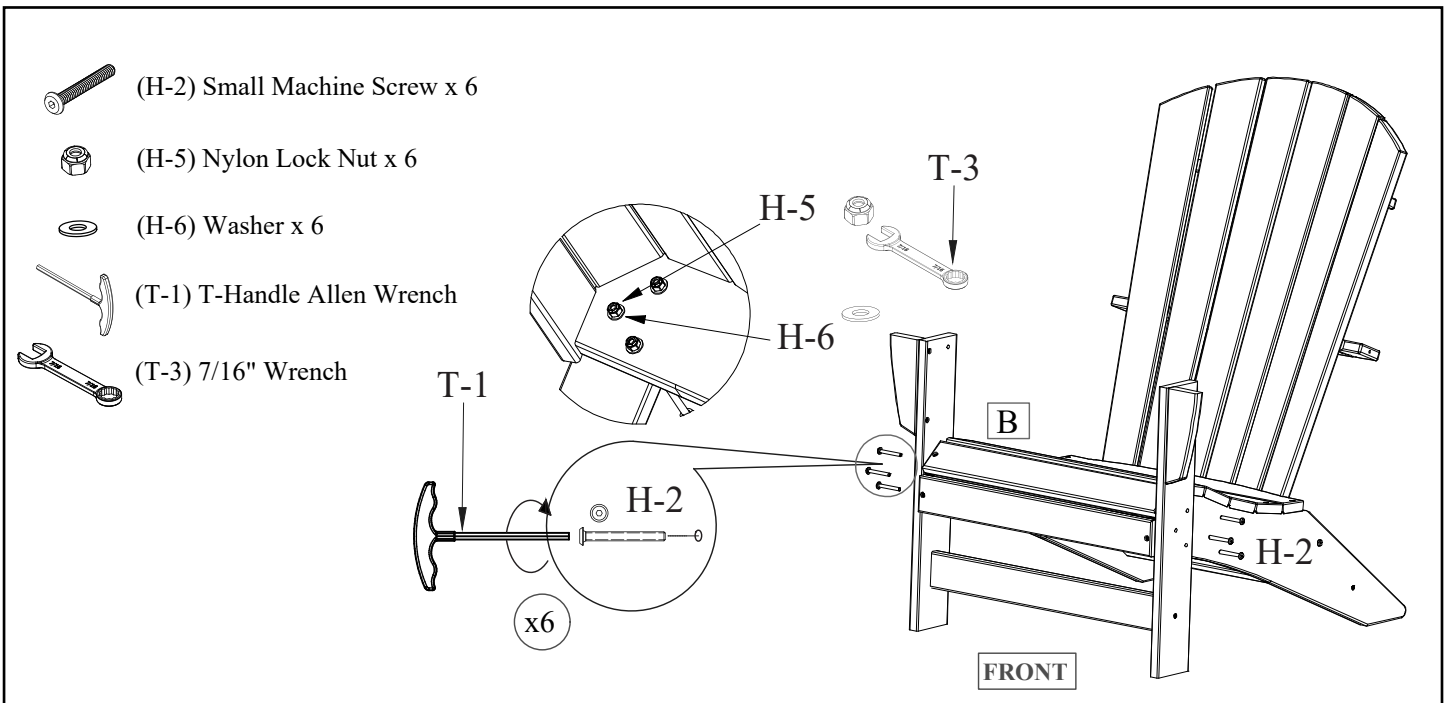

## Step 4



Align the three holes in the front leg assembly with the front of the Seat Assembly (B). Insert three Small Machine Screw (H-2) into the holes on each side and using the Nylon Lock Nut (H-5) and Washer (H-6) stacking the hardware in the order as shown on the inside of the seat. Tighten the screws with the T-Handle Allen Wrench (T-1) while holding Nylon Lock Nut (H-5) in place with the 7/16" Wrench (T-3). Complete for both sides.

# Assembly Steps

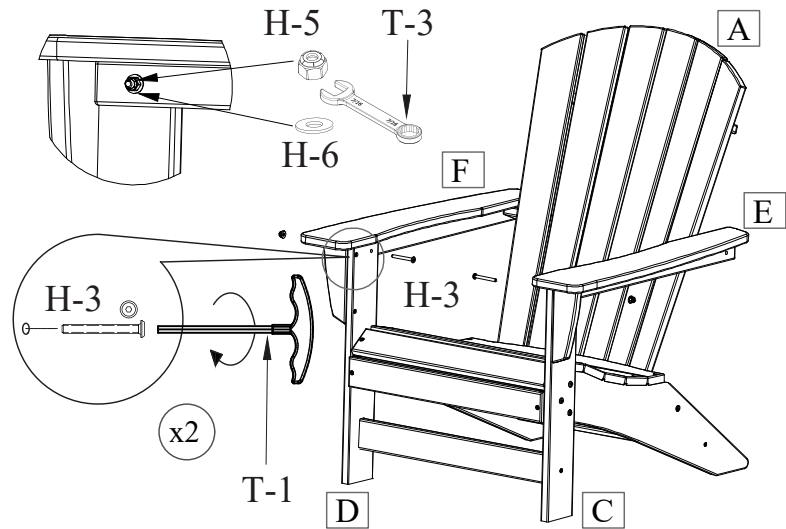

## Step 5

-  (H-3) Large Machine Screw x 2
-  (H-5) Nylon Lock Nut x 2
-  (H-6) Washer x 2
-  (T-1) T-Handle Allen Wrench
-  (T-3) 7/16" Wrench



5.1 Rest the Left Arm (E) on the Left Front Leg (C) and left side of the Back Brace (A). The arm should be on the outside of the leg. Fasten the arm down using a Large Machine Screw (H-3) on the leg side and tighten using the Nylon Lock Nut (H-5) and Washer (H-6) under the arm. Tighten the screws with the T-Handle Allen Wrench (T-1) while holding the Nylon Lock Nut (H-5) in place with the 7/16" Wrench (T-3). Do not yet fully tighten. Repeat this process for the Right Arm (F).

## Step 6

-  (H-1) Lag Screw x 2
-  (T-1) T-Handle Allen Wrench

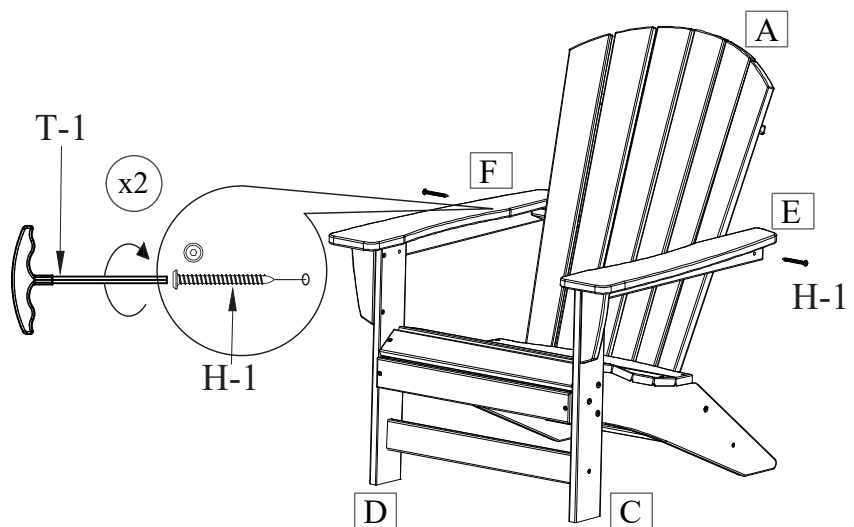

Fasten Left Arm (E) and Right Arm (F) to the Back Brace (A) using a Lag Screw (H-1) on either side with the T-Handle Allen Wrench (T-1). Fully tighten all hardware from this step and all previous steps. DO NOT OVER TIGHTEN.



# Assembly Steps

## Step 8

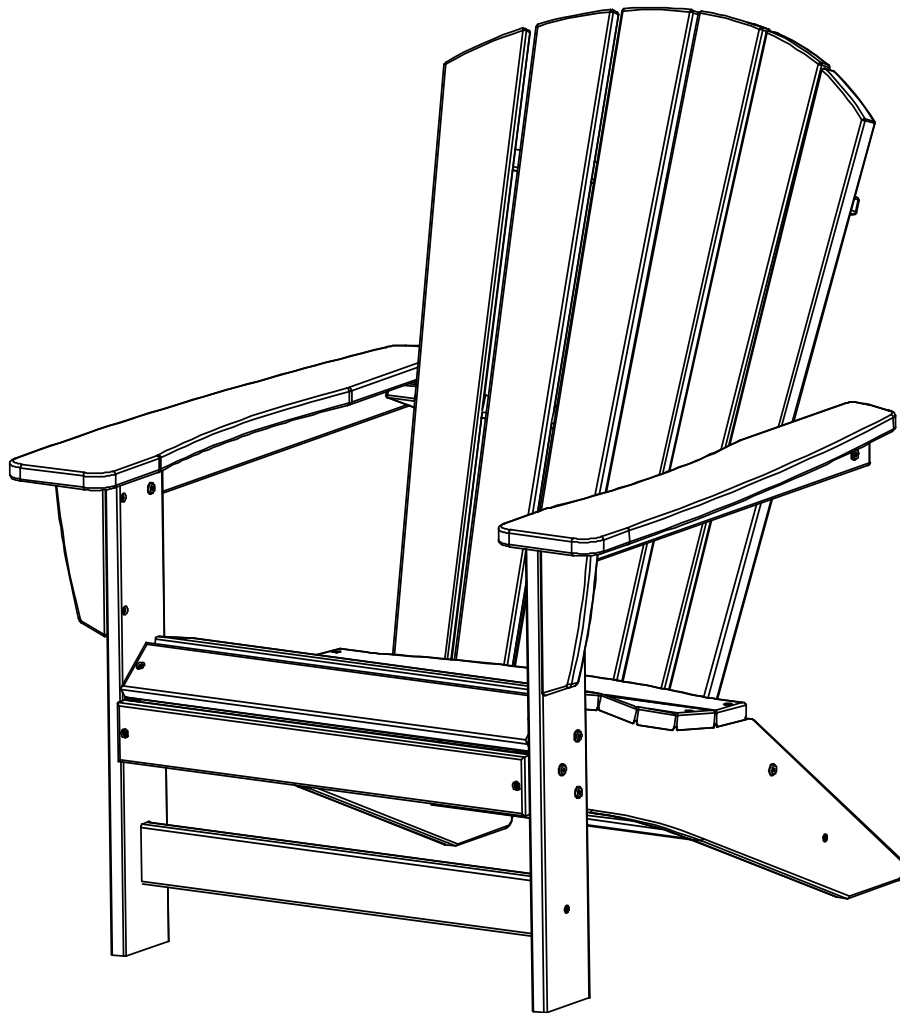

Assembly is now complete and the product is ready for use. NOTE: Hardware may loosen over time. Periodically check that all connections remain tight and adjust as needed.

# WORLD MARKET®

## Assembly Instructions

### Recycled Plastic Side Table

SKU 630949

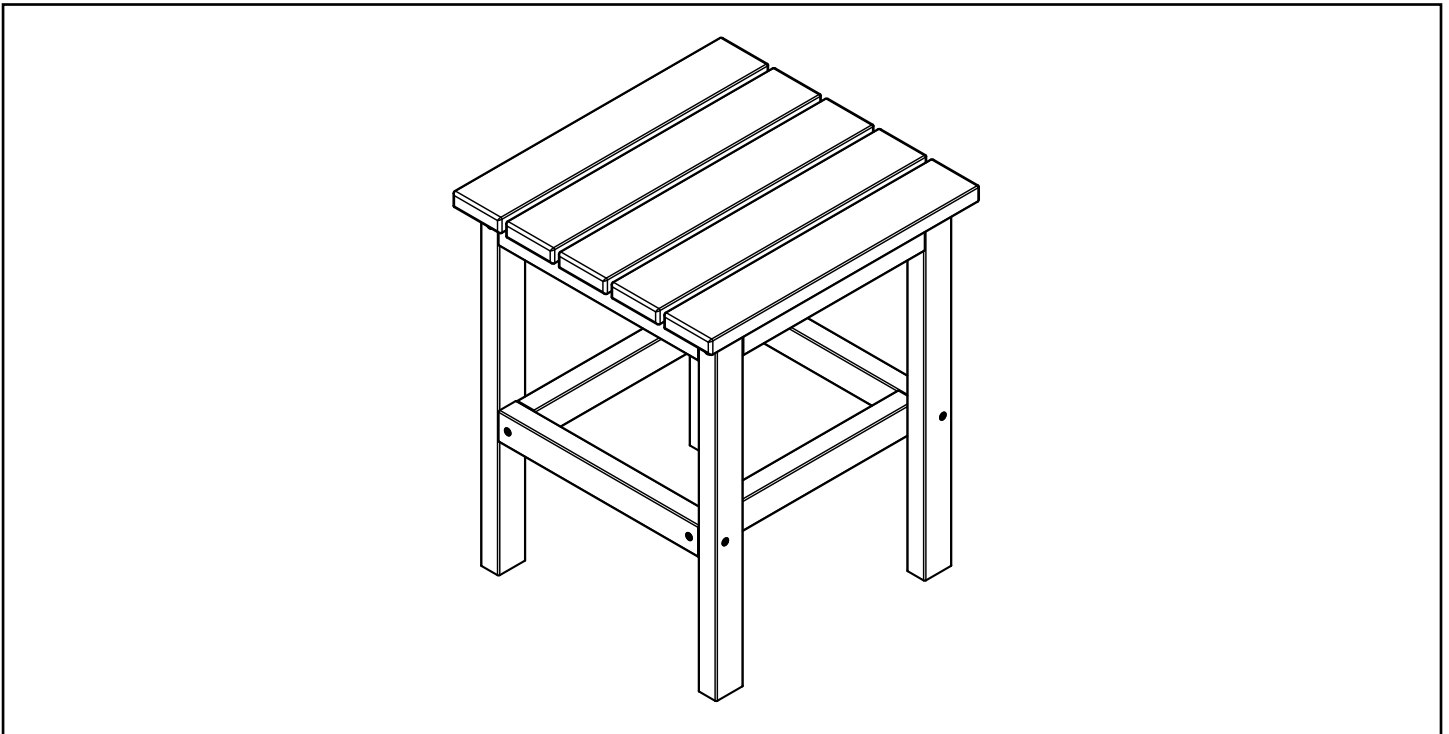

Thank you for your purchase. If you have any questions pertaining to the assembly of this furniture piece, please contact the nearest World Market store. If you are not near a store, please call our customer service call center toll free at 877-967-5362 for assistance.

ALL PRODUCTS SOLD AT WORLD MARKET ARE NOT  
FOR COMMERCIAL USE AND ARE INTENDED FOR  
RESIDENTIAL USE ONLY.

## Component List

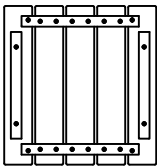
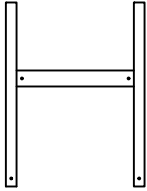
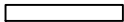
LABEL	PICTURE	DESCRIPTION	QTY.
A		Table Top	1
B		Leg Assembly	2
C		Brace	2

## Hardware List

LABEL	PICTURE	DESCRIPTION	QTY.
H-1		Phillips Head Screw 2"	12

## Tool List

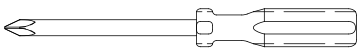
LABEL	PICTURE	DESCRIPTION	QTY.
T-1		#2 Phillips Screwdriver (Not Included)	

# Assembly Preparation

## Before Beginning:

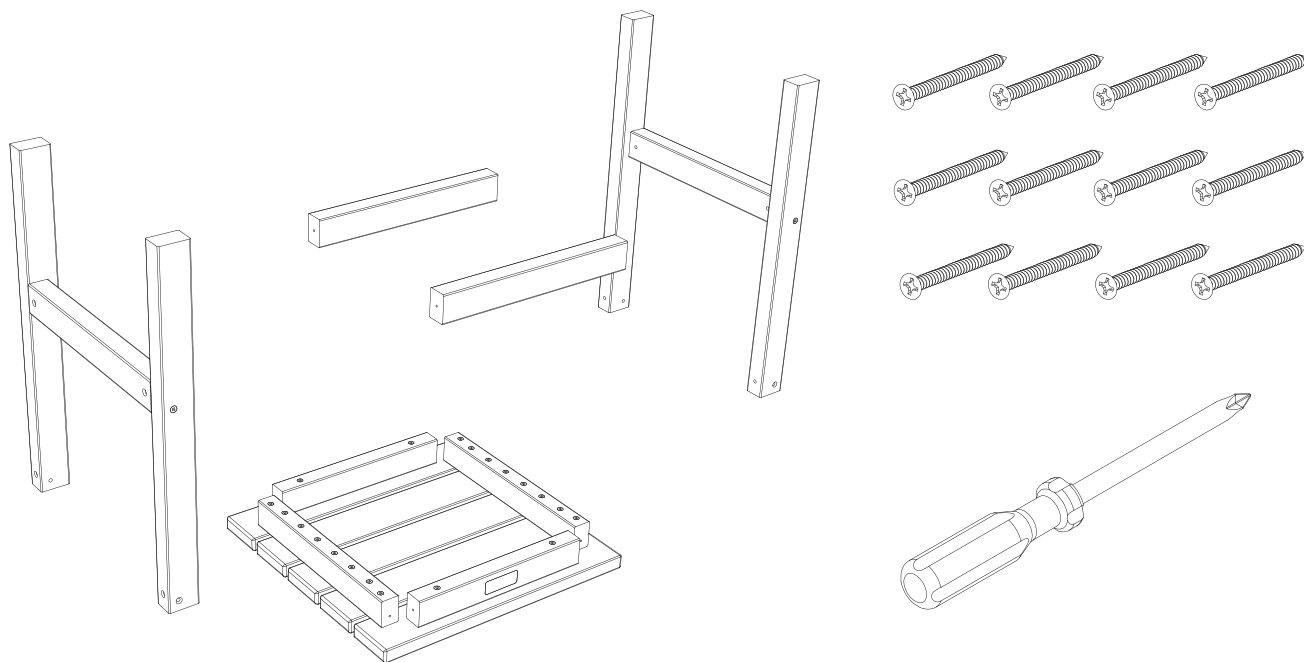

Unpack all hardware bags and components to ensure you have all parts. Take note of bolt hardware size differences and components that may have directional labels (Example: TOP or FRONT).



Read the assembly instructions, cover-to-cover. Save any **Care and Maintenance** instructions pages for after the assembly has been completed.



It is always recommended to have 2 adults on hand for assembly.



Do not assemble on hard, abrasive flooring or carpeted surfaces that can damage or get caught in the components during assembly.



Assemble on a clean non-marring surface (such as the product's packing foam).

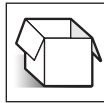

Do not discard any packaging until the product has been fully assembled.



In case of missing parts, please contact your nearest World Market store or call our customer service call center at 1-877-967-5362.



**WARNING:** Small parts are a choking hazard. Adult supervision is required before, during, and after assembly.

# Assembly Steps

## Step 1

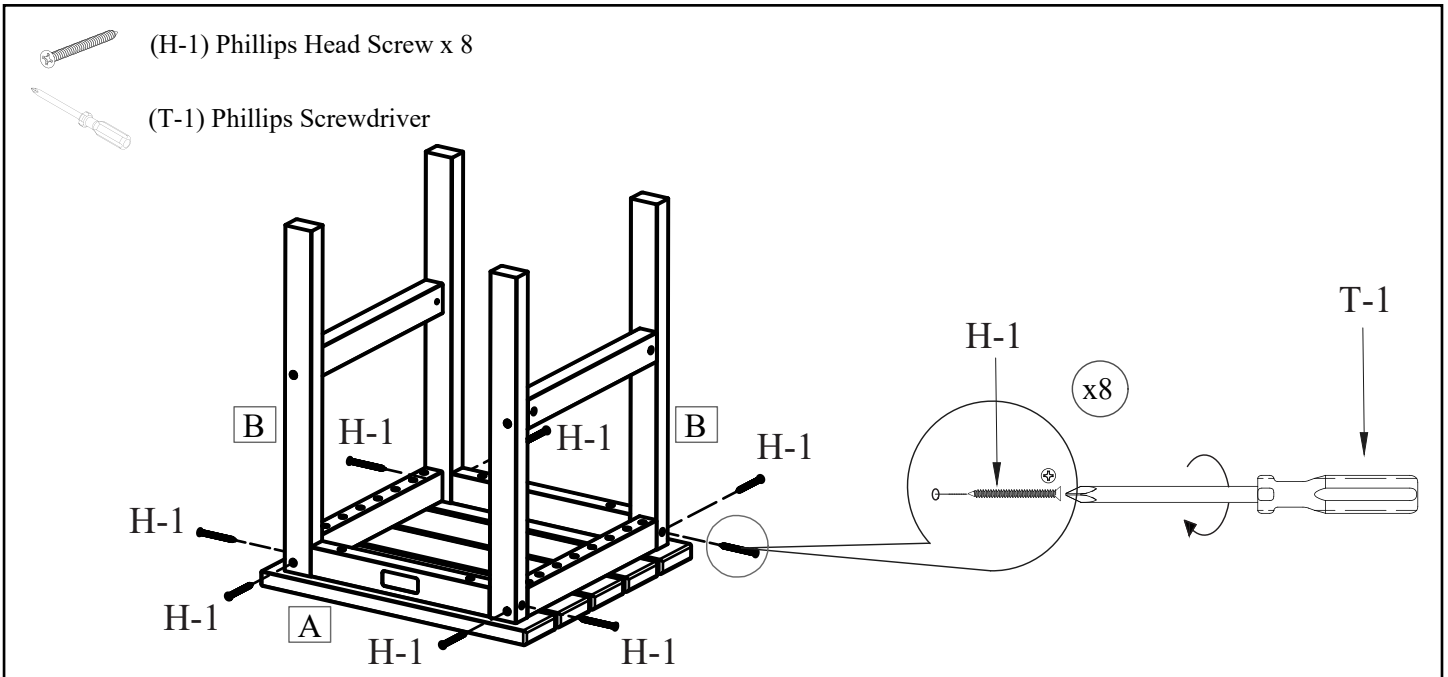

Place the Tabletop (A) upside down on a flat surface. Install the first Leg Assembly (B) onto the tabletop. Fasten using four Phillips Head Screws (H-1) and a Phillips Screwdriver (T-1). Repeat for the other Leg Assembly (B). Do not yet fully tighten.

## Step 2

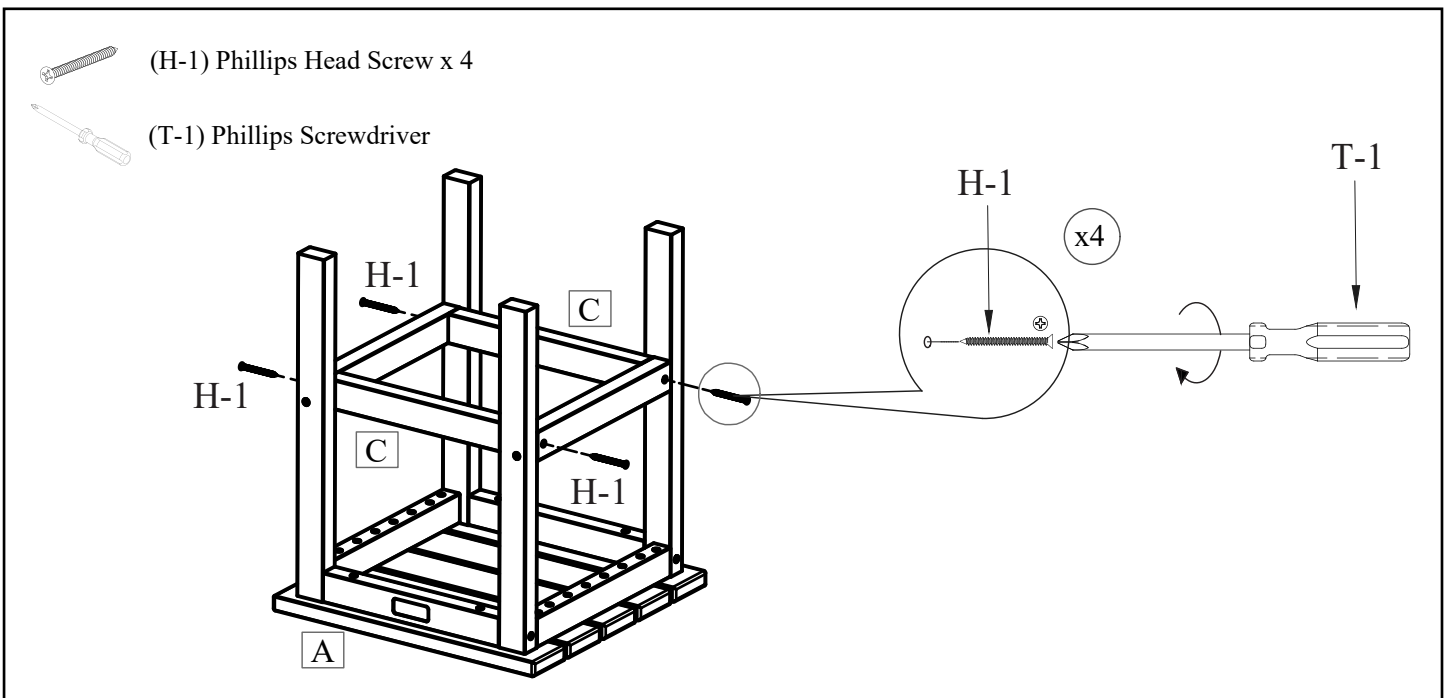

Place the Brace (C) in place and fasten using two Phillips Head Screws (H-1) and a Phillips Screwdriver (T-1). Repeat for the other Brace (C). Fully tighten all hardware from this step and all previous steps. **DO NOT OVER TIGHTEN.**

# Assembly Steps

## Step 3

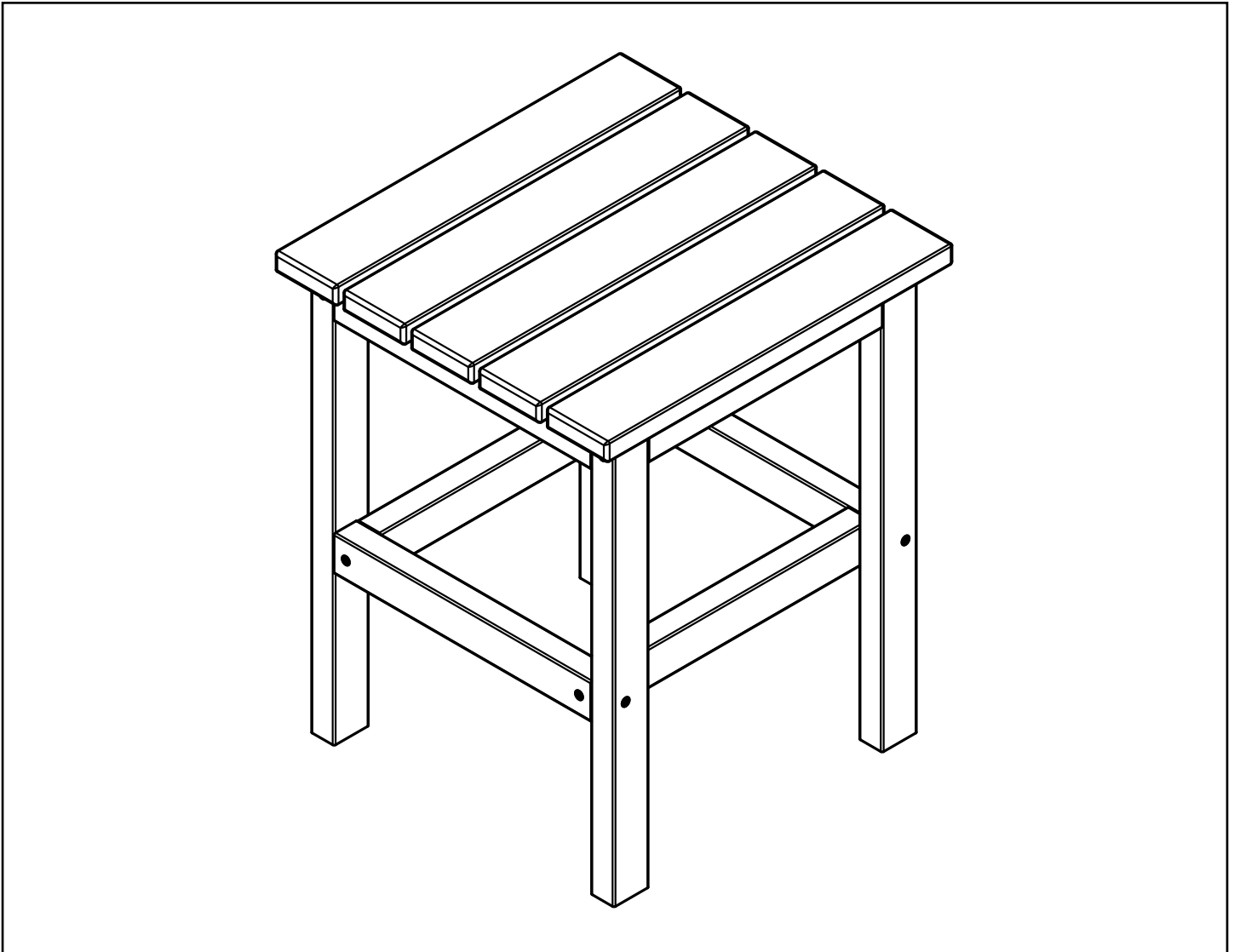

Assembly is now complete and the product is ready for use. NOTE: Hardware may loosen over time. Periodically check that all connections remain tight and adjust as needed.

# Outdoor Warnings



All products sold at World Market are not for commercial use and are intended for residential use only.



**IMPORTANT: ALWAYS** store furniture or use appropriate furniture covers during cold or inclement weather or during periods of non-use.

# Outdoor Care & Maintenance



**DO NOT** put hot items directly on furniture surface.



**DO NOT** clean furniture with harsh cleansers or polish.



**DO NOT** place furniture near outdoor exhaust vents.



**DO NOT** write on furniture without a padded barrier to protect the surface.

## For Outdoor Products with Upholstery



Dust and pick up spills using a clean, non-colored, lint-free dry cloth.



Treat any spills or stains immediately. **DO NOT** let it soak into the fabric.



Solid and liquid stains can be spot cleaned using a clean white cotton cloth. We also recommend our Outdoor Cushion Cleaner (sold separately). Scan the QR code to the right of this message.

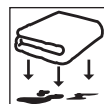

Dab the stain with light, even pressure. **DO NOT** rub the stain when spot cleaning.

## For Outdoor Products with Wood

**CAUTION:** As with any wood, the color may fade when left in direct sunlight or inclement weather. Minor cracking may occur with age. These are naturally occurring features of wood and do not affect product performance.



SCAN HERE FOR  
OUTDOOR FURNITURE FINISH



We recommend using our Outdoor Wood Furniture Finish (sold separately) to help preserve and protect the wood and finish. Scan the QR code above for more information.